



Waterproofing system for waterproof-concrete joints

Triflex JWS

System drawing

Variant 1: Controlled crack joint, construction joint, expansion joint – surface

System build-up – Detail A

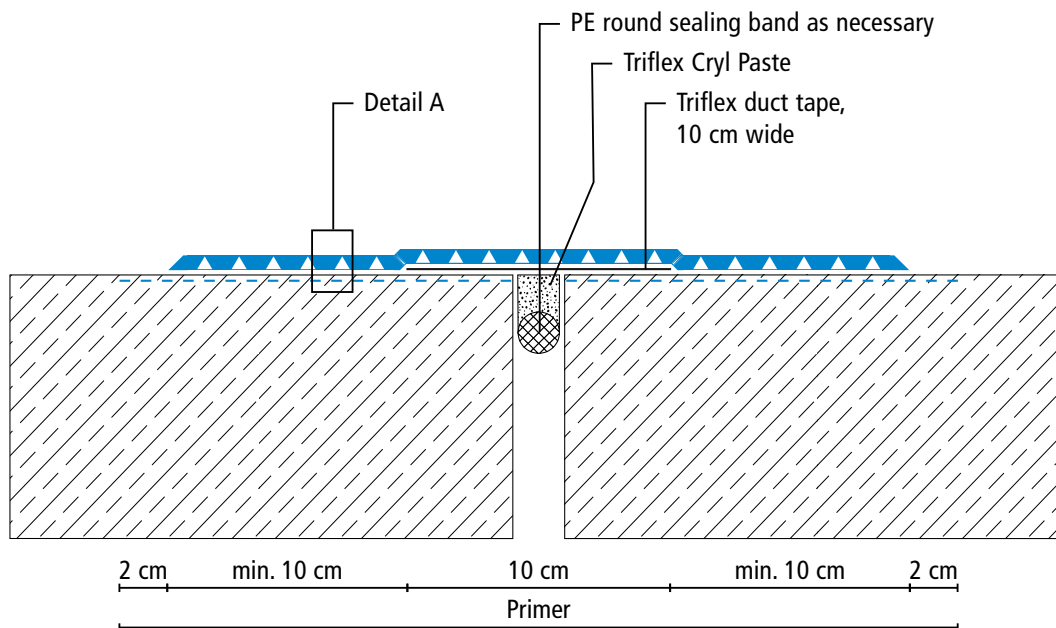
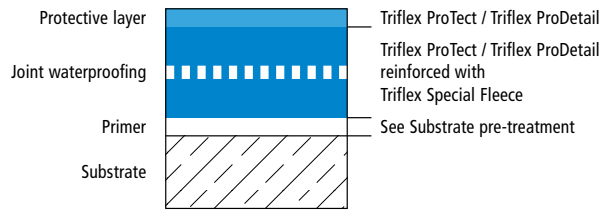

Triflex JWS



System drawing

Variant 1: Controlled crack joint, construction joint, expansion joint – wall junction

System build-up – Detail A

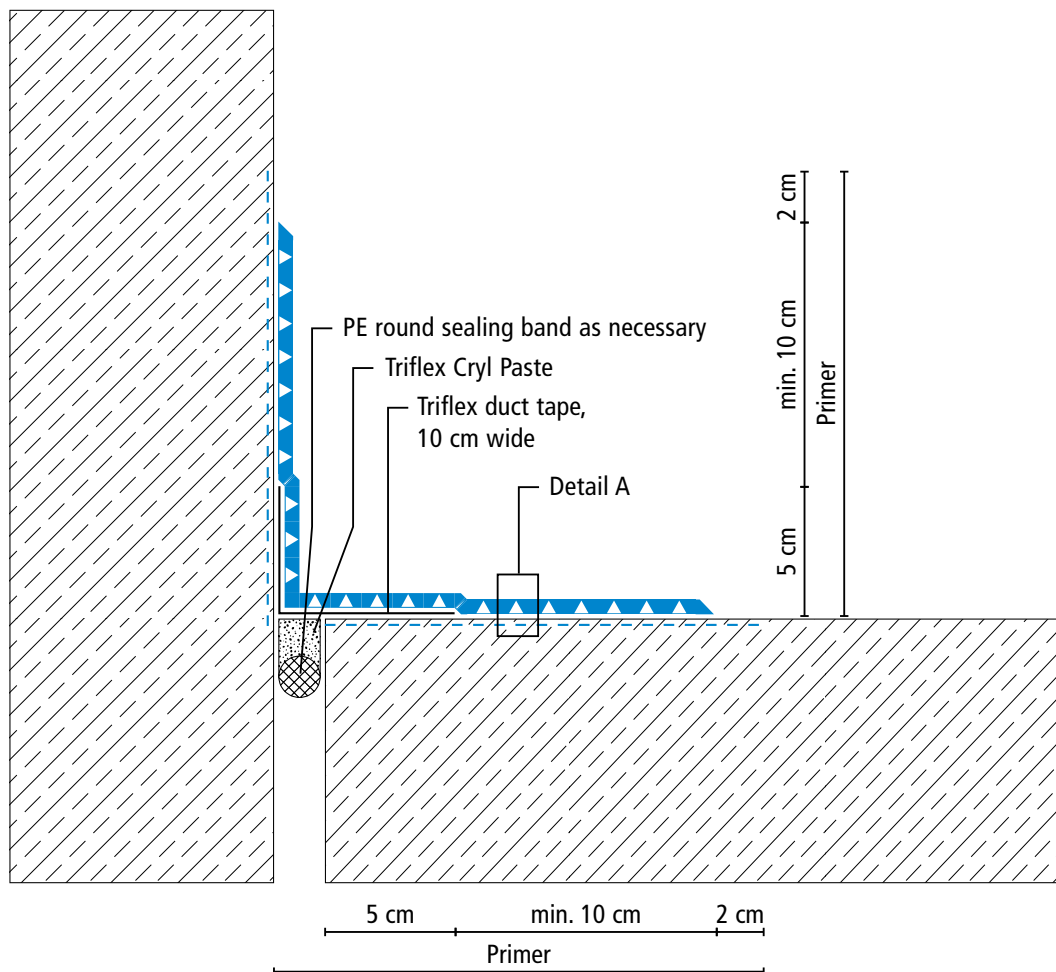
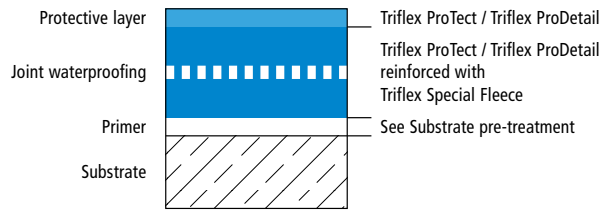

Triflex JWS



System drawing

Variant 2: Expansion joint – surface

System build-up – Detail B

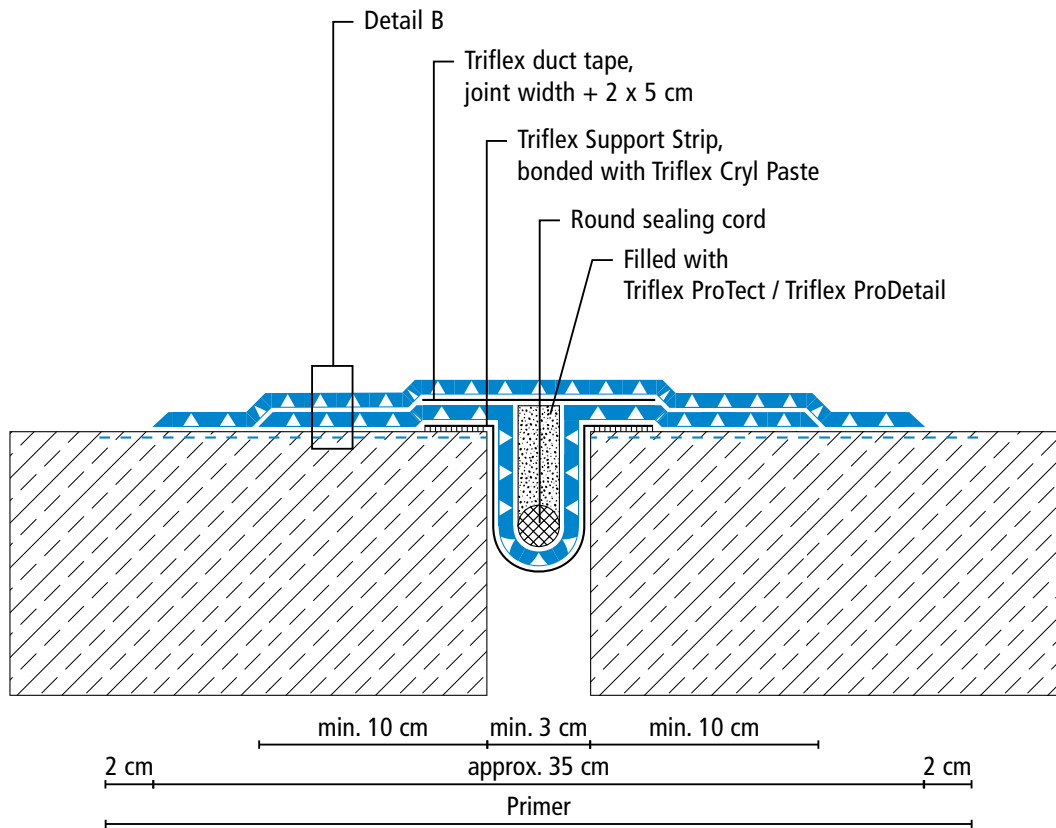
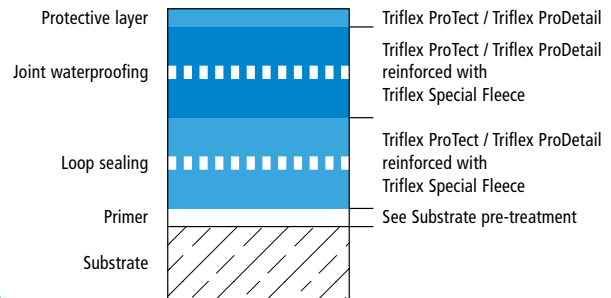

Triflex JWS



System drawing

Variant 2: Expansion joint – wall junction

System build-up – Detail B

